



G. MONDINI S.p.A.
DOSATRICI-CONFEZIONATRICI AUTOMATICHE

25033 Cologne (Brescia) Italia
via Brescia 5/7
tel. 030 70560
fax 030 7056250 - 030 7050168
e-mail: info@gmondini.com
www.gmondini.com

Rappresentati da: / Represented by: / Représenté par: / Vertreten von:

FRESH M.A.P. SYSTEM

CASE READY MEATS
ARE ALREADY HERE!
It only Makes Sense

FRESH
M.A.P.
SYSTEM

G. MONDINI S.p.A.
DOSATRICI-CONFEZIONATRICI AUTOMATICHE



FRESH M.A.P. SYSTEM

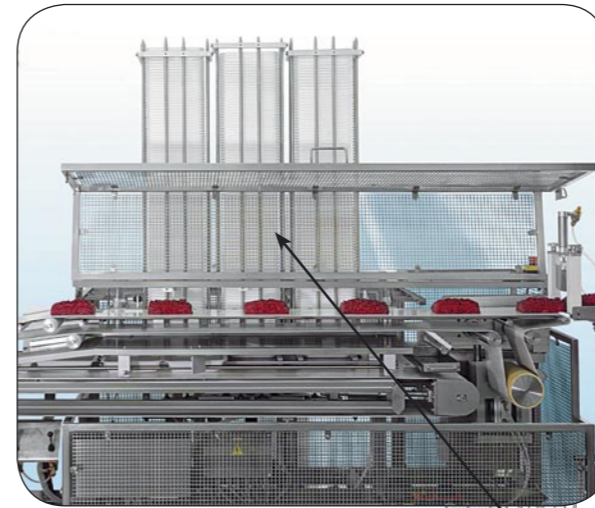
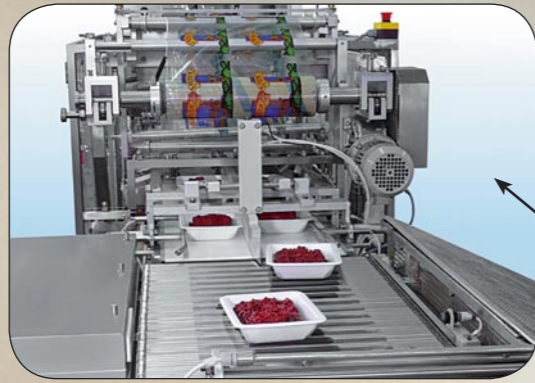

PRODUZIONE DA 15 A 120 CONFEZIONI AL MINUTO
PRODUCTION FROM 15 TO 120 PACKAGES PER MINUTE
LEISTUNG VON 15 BIS 120 PACKUNGEN PRO MINUTE
PRODUCTION DE 15 PAR 120 BARQUETTES MINUTE

CONTENITORI POLISTIROLO ESPANSO BARRIERATI

termosaldati con
FILM BARRIERATO
TERMORETRAIBILE
• CARNE • PESCE •
• PASTA FRESCA • VEGETALI •

STYROFOAM TRAYS

heatseal with
SHRINK - BARRIERED - LID
• MEAT • FISH •
• FRESH DOUGH • VEGETABLE •

STYROPORSCHALEN

siegelbar mit
SCHRUMPF BARRIEREFOLIE
• FLEISCH • FISCH •
• FRISCHE TEIGWAREN • GEMÜSE •

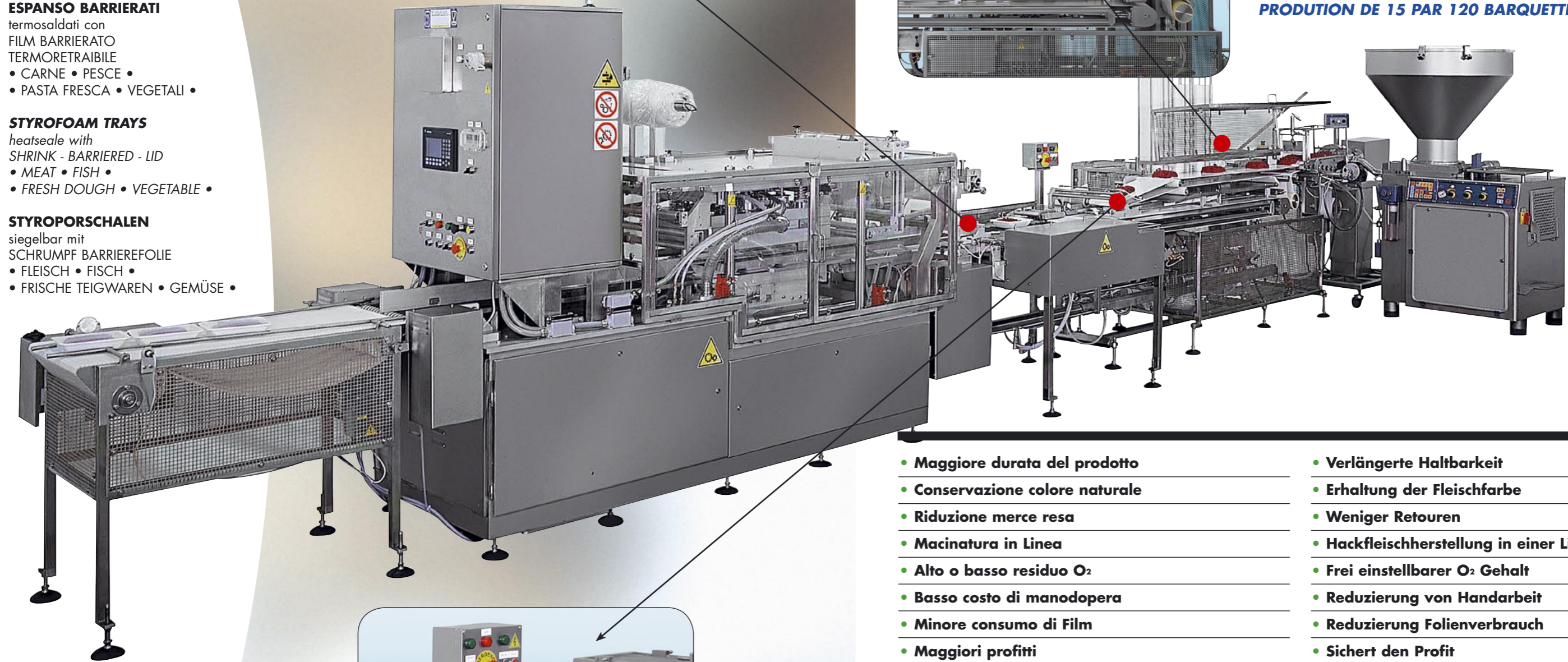

BARQUETTES PSE BARRIERE

thermoscellées avec
FILM BARRIERE
TERMORETRACTABLE
• VIANDE • POISSON •
• PATES FREICHES •
• LEGUMES •

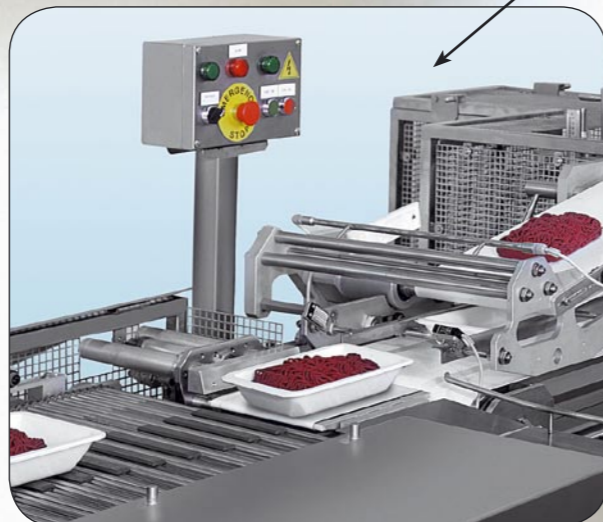

Brevetto- Patent
IT 1216516
EP 0334266
US 4974392
US 5475965

- Maggiore durata del prodotto
- Conservazione colore naturale
- Riduzione merce resa
- Macinatura in Linea
- Alto o basso residuo O₂
- Basso costo di manodopera
- Minore consumo di Film
- Maggiori profitti

- Extended Shelf Life
- Natural Color Retention
- Lower Returns
- In-line Grinding
- High or Low O₂ Level
- Handling Reduced
- Less Film Usage
- Improved Profit

- Verlängerte Haltbarkeit
- Erhaltung der Fleischfarbe
- Weniger Retouren
- Hackfleischherstellung in einer Linie
- Frei einstellbarer O₂ Gehalt
- Reduzierung von Handarbeit
- Reduzierung Folienverbrauch
- Sichert den Profit

- Conservation Prolongée
- Couleur Naturelle Préservée
- Retours Réduits
- Hachage en Ligne
- Haut ou Bas Niveau O₂
- Main d'Oeuvre Réduite
- Film Economisé
- Profit Augmenté